

Chain Block POWERTEX PCB-S2

Product information



The Powertex PCB-S2 Hoist is a high-quality chain block designed to provide durability, safety, and ease of operation. With its ergonomic hand chain and advanced features, this chain hoist ensures smooth and efficient lifting for various industrial applications.

Product benefits:

- **Enhanced safety:** each hoist undergoes dynamic proof load testing at 1.5 times the Working Load Limit (WLL) before leaving the factory, ensuring maximum safety and reliability. The hoist is equipped with a well-covered automatic load reaction brake and features double safety with two brake pawls and four brake springs, exceeding EN 13157 requirements. The load chain is calibrated, proof load tested and meets the requirements of EN 818-7.
- **Smooth and efficient Operation:** the compact and lightweight construction, combined with a sprocket wheel equipped with needle bearings and a drive shaft supported by needle and slide bearings, ensures smooth and efficient operation. The fine-calibrated load chain offers quiet and seamless performance.
- **Quality load chain:** the load chain complies with the EN818-7 T(8) standard and features a Chrome 6-free electro-galvanized surface finish to protect it from corrosion.
- **Easy positioning and safe hooks:** swivel hooks at both ends make in-line positioning easy. The hooks are designed to open at overload instead of breaking, enhancing safety. Heavy-duty steel safety latches and deformation check dots forged into the side of the hooks allow for easy overload detection.
- **Convenient maintenance and documentation:** each hoist is RFID-equipped for easy identification and tracking. [Read more](#)

Material: Durable all steel construction

Marking: According to standard, CE-marked, UKCA-marked, POWERTEX, Model, WLL, Chain, Serial number, User manual/QR code

Temperature range: -10°C up to +50°C

Finish: Red powder coated body and plated frame components

Standard: EN 13157, EN 818-7

Safety factor: 4:1

Chain Block POWERTEX PCB-S2

Blueprint

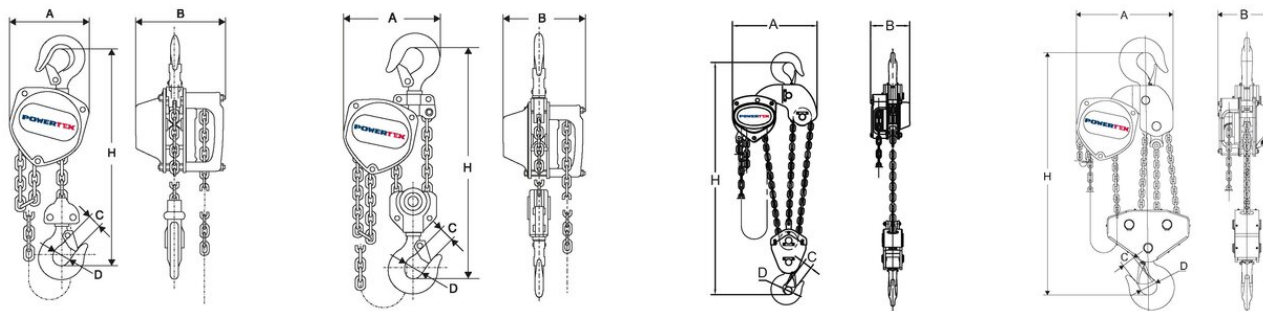

Technical data

Part code	WLL ton	Lifting height m	Number of falls	Model	Load chain mm	Hand chain mm	Hand force max. kg	A mm	B mm	C mm	D mm	H min mm	Weight kg
500100030200670	0.25	2	1	PCB-S2/250KG PHCA	4,0 x 12,0	5,0 x 23,7	23.5	108	106	20	30	260	4.65
500100030300670	0.25	3	1	PCB-S2/250KG PHCA	4,0 x 12,0	5,0 x 23,7	23.5	108	106	20	30	260	5.9
500100030600670	0.25	6	1	PCB-S2/250KG PHCA	4,0 x 12,0	5,0 x 23,7	23.5	108	106	20	30	260	6.4
500100030400670	0.25	4	1	PCB-S2/250KG PHCA	4,0 x 12,0	5,0 x 23,7	23.5	108	106	20	30	260	7.15
500100030500670	0.25	5	1	PCB-S2/250KG PHCA	4,0 x 12,0	5,0 x 23,7	23.5	108	106	20	30	260	8.4
500100031000670	0.25	10	1	PCB-S2/250KG PHCA	4,0 x 12,0	5,0 x 23,7	23.5	108	106	20	30	260	14.1
500100050300670	0.5	3	1	PCB-S2/500KG PHCA	5,0 x 15,0	5,0 x 23,7	24.9	130	128	22	34	280	9.8
500100050400670	0.5	4	1	PCB-S2/500KG PHCA	5,0 x 15,0	5,0 x 23,7	24.9	130	128	22	34	280	11.2
500100050600670	0.5	6	1	PCB-S2/500KG PHCA	5,0 x 15,0	5,0 x 23,7	24.9	130	128	22	34	280	14
500100050500670	0.5	5	1	PCB-S2/500KG PHCA	5,0 x 15,0	5,0 x 23,7	24.9	130	128	22	34	280	15.1
500100050700670	0.5	7	1	PCB-S2/500KG PHCA	5,0 x 15,0	5,0 x 23,7	24.9	130	128	22	34	280	15.4
500100051000670	0.5	10	1	PCB-S2/500KG PHCA	5,0 x 15,0	5,0 x 23,7	24.9	130	128	22	34	280	19.6
500100051500670	0.5	15	1	PCB-S2/500KG PHCA	5,0 x 15,0	5,0 x 23,7	24.9	130	128	22	34	280	28
500100100300670	1	3	1	PCB-S2/1000KG PHCA	6,3 x 19,0	5,0 x 23,7	28.4	150	145	26	39	330	11.7
500100100500670	1	5	1	PCB-S2/1000KG PHCA	6,3 x 19,0	5,0 x 23,7	28.4	150	145	26	39	330	13.3
500100100400670	1	4	1	PCB-S2/1000KG PHCA	6,3 x 19,0	5,0 x 23,7	28.4	150	145	26	39	330	13.45
500100100600670	1	6	1	PCB-S2/1000KG PHCA	6,3 x 19,0	5,0 x 23,7	28.4	150	145	26	39	330	16.95
500100100900670	1	9	1	PCB-S2/1000KG PHCA	6,3 x 19,0	5,0 x 23,7	28.4	150	145	26	39	330	22.2

Chain Block POWERTEX PCB-S2

Technical data

Part code	WLL ton	Lifting height m	Number of falls	Model	Load chain mm	Hand chain mm	Hand force max. kg	A mm	B mm	C mm	D mm	H min mm	Weight kg
500100101200670	1	12	1	PCB-S2/1000KG PHCA	6,3 x 19,0	5,0 x 23,7	28.4	150	145	26	39	330	27.5
500100101500670	1	15	1	PCB-S2/1000KG PHCA	6,3 x 19,0	5,0 x 23,7	28.4	150	145	26	39	330	32.7
500100200250670	2	2.5	1	PCB-S2/2000KG PHCA	8,0 x 24,0	5,0 x 23,7	34.3	185	175	35	49	385	17.58
500100200300670	2	3	1	PCB-S2/2000KG PHCA	8,0 x 24,0	5,0 x 23,7	34.3	185	175	35	49	385	18.9
500100200600670	2	6	1	PCB-S2/2000KG PHCA	8,0 x 24,0	5,0 x 23,7	34.3	185	175	35	49	385	19.5
500100201000670	2	10	1	PCB-S2/2000KG PHCA	8,0 x 24,0	5,0 x 23,7	34.3	185	175	35	49	385	35
500100201200670	2	12	1	PCB-S2/2000KG PHCA	8,0 x 24,0	5,0 x 23,7	34.3	185	175	35	49	385	39.6
500100300300670	3	3	2	PCB-S2/3000KG PHCA	7,1 x 21,0	5,0 x 23,7	34.3	220	158	37	50	510	28.9
500100300600670	3	6	2	PCB-S2/3000KG PHCA	7,1 x 21,0	5,0 x 23,7	34.3	220	158	37	50	510	28.9
500100300400670	3	4	2	PCB-S2/3000KG PHCA	7,1 x 21,0	5,0 x 23,7	34.3	220	158	37	50	510	30.85
500100300500670	3	5	2	PCB-S2/3000KG PHCA	7,1 x 21,0	5,0 x 23,7	34.3	220	158	37	50	510	31.9
500100300800670	3	8	2	PCB-S2/3000KG PHCA	7,1 x 21,0	5,0 x 23,7	34.3	220	158	37	50	510	35.65
500100301000670	3	10	2	PCB-S2/3000KG PHCA	7,1 x 21,0	5,0 x 23,7	34.3	220	158	37	50	510	42.55
500100301200670	3	12	2	PCB-S2/3000KG PHCA	7,1 x 21,0	5,0 x 23,7	34.3	220	158	37	50	510	46.45
500100301500670	3	15	2	PCB-S2/3000KG PHCA	7,1 x 21,0	5,0 x 23,7	34.3	220	158	37	50	510	52.3
500100302000670	3	20	2	PCB-S2/3000KG PHCA	7,1 x 21,0	5,0 x 23,7	34.3	220	158	37	50	510	62.05
500100500200670	5	2	2	PCB-S2/5000KG PHCA	9,0 x 27,0	5,0 x 23,7	37.2	255	183	43	60	615	34.45
500100500300670	5	3	2	PCB-S2/5000KG PHCA	9,0 x 27,0	5,0 x 23,7	37.2	255	183	43	60	615	37.1
500100500400670	5	4	2	PCB-S2/5000KG PHCA	9,0 x 27,0	5,0 x 23,7	37.2	255	183	43	60	615	39.75
500100500500670	5	5	2	PCB-S2/5000KG PHCA	9,0 x 27,0	5,0 x 23,7	37.2	255	183	43	60	615	42.4

Chain Block POWERTEX PCB-S2

Technical data

Part code	WLL ton	Lifting height m	Number of falls	Model	Load chain mm	Hand chain mm	Hand force max. kg	A mm	B mm	C mm	D mm	H min mm	Weight kg
500100500600670	5	6	2	PCB-S2/5000KG PHCA	9,0 x 27,0	5,0 x 23,7	37.2	255	183	43	60	615	45.05
500100500700670	5	7	2	PCB-S2/5000KG PHCA	9,0 x 27,0	5,0 x 23,7	37.2	255	183	43	60	615	47.7
500100500800670	5	8	2	PCB-S2/5000KG PHCA	9,0 x 27,0	5,0 x 23,7	37.2	255	183	43	60	615	59.1
500100501000670	5	10	2	PCB-S2/5000KG PHCA	9,0 x 27,0	5,0 x 23,7	37.2	255	183	43	60	615	67.9