

Column Mounted Jib Crane with Clamp Around

Product information

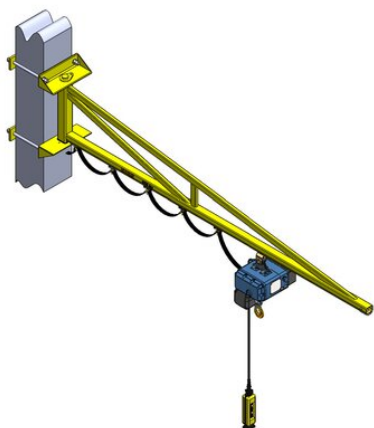

This column mounted jib crane consists of an arm and a pair of brackets that can be clamped around an existing building column/stanchion/pillar. This jib crane provides the most free-running travel along the arm and gives excellent flexibility for rotations of 180°.

Column fixing is done with clamping brackets.

Features:

- Capacity up to 1000 kg
- Outreach up to 6 m
- Electrical festoon supply: runs inside the arm track

... [Read more](#)

Finish: Zinc plated/powder coating. Stainless steel 304/316

Column Mounted Jib Crane with Clamp Around

Blueprint

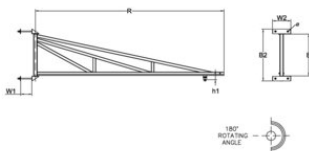

Technical data

Part code	WLL ton	Length m	Profile No.	Bolt Ø mm	B mm	Rmm mm	B2mm mm	h1mm mm	W1 mm	W2 mm
602124J053C	0.08	3	24,000	M20	500	3,000	720	65	500	380
602124J064C	0.08	4	24,000	M20	600	4,000	820	65	500	380
602124J095C	0.08	5	24,000	M20	900	5,000	1,120	65	500	380
602125J096C	0.08	6	25,000	M20	900	6,000	1,120	77	500	380
602125J053C	0.125	3	25,000	M20	500	3,000	720	77	500	380
602125J064C	0.125	4	25,000	M20	600	4,000	820	77	500	380
602125J095C	0.125	5	25,000	M20	900	5,000	1,120	77	500	380
602125J106C	0.125	6	25,000	M20	1,000	6,000	1,220	77	500	380
602125J063C	0.25	3	25,000	M20	600	3,000	820	77	500	380
602125J084C	0.25	4	25,000	M20	800	4,000	1,020	77	500	380
602126J095C	0.25	5	26,000	M20	900	5,000	1,120	94	500	380
602126J106C	0.25	6	26,000	M20	1,000	6,000	1,220	94	500	380
602126J083C	0.5	3	26,000	M20	800	3,000	1,020	94	500	380
602126J094C	0.5	4	26,000	M20	900	4,000	1,120	94	500	380
602127J105C	0.5	5	27,000	M20	1,000	5,000	1,220	123	500	380
602127J116C	0.5	6	27,000	M20	1,100	6,000	1,320	123	500	380
602127J093C	1	3	27,000	M20	900	3,000	1,120	123	500	380
602127J104C	1	4	27,000	M20	1,000	4,000	1,220	123	500	380