

Top Rack Jack

Product information



- 5 models of the top rack jacks are available with different capacities between 1,5 and 20 tons.
- The gear wheels, the pinions and the rack are made of heat-treated steel.
- Lifting is controlled by a crank operating through a ratchet wheel with a double retaining catch, giving the jack additional safety.
- Lowering is by a locked ratchet, holding the load by friction discs.
- The folding handle of the crank reduces the overall dimension of the jack during transport.
- Full working load limit can be applied to head or toe except for the model 16 tons and 20 tons where the capacity is reduced of 30% on the side toe. [... Read more](#)

Marking: CE-marked

Top Rack Jack

Blueprint

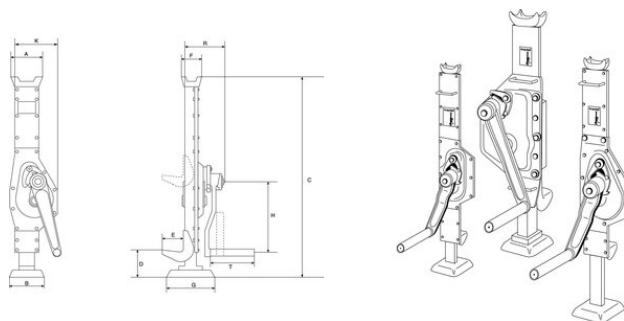

Technical data

Part code	WLL ton	Model	Hand force max. kg	A mm	B mm	C mini mm mm	D mini mm mm	E mm	F mm	G, mm	H, mm	K mm	Rmm mm	T mm	Lift Z mm mm	Weight kg
5205196478	1.5	BT 1,5	30	81	100	600	70	55	46	110	225	147	119	113	300	18
5205196488	3	BT 3	35	83	130	735	70	60	45	138	249	168	129	130	355	20
5205196498	5	BT 5	40	108	140	735	80	71	68	170	249	190	146	130	345	28
5205196508	10	BT 10	58	124	140	800	100	86	76	170	300	250	168	239	390	46